

NX Graphical OCS

New, Low-cost Graphical OCS with Embedded Ethernet

The NX Graphical OCS series is a low cost, high-performance all-in-one controller with embedded features such as Ethernet, CompactFLASH® and Web server. It uses Horner's industry-recognized Cscape software and the complete selection of SmartStack I/O—that can be snapped on the back of the NX controller—and SmartStix remote I/O. OCS (Operator Control Station) is a robust, reliable control product that combines a traditional controller...programmed in ladder logic...operator interface, I/O and networking into an integrated, all-in-one unit using a single software package.

An NX Graphical OCS can control many different types of machines and processes—from medium to large applications—requiring an operator interface, controller, I/O and networking. The NX has 0.1mS/K ladder scan rate, 256K ladder memory, supports 4096 digital and 1024 analog I/O points and offers two I/O options for local and remote requirements. The NX also has Internet capabilities...including programming over the Internet to remote locations, and hosting Web pages and FTP sites. Available models include 240 x 128 and 128 x 64 backlit LCD graphical screens and each NX model has 10 function keys with LEDs plus dedicated soft keys. Prices start under \$700 for the 128 x 64 graphical screen model with 256K ladder memory and CompactFLASH support...and under \$800 with embedded Ethernet, Web server and built-in high speed counters.

CompactFLASH Stores Data and Allows Easy Program Updates

The NX Graphical OCS has a built-in CompactFLASH slot that allows users to conveniently set up the controller to store machine or process data (up to 2GB memory). In addition, programs and updates can be loaded through a CompactFLASH card. This is a real advantage for OEMs or those supporting distant sites because end users can simply and safely plug in a CompactFLASH card and update the program.

Connect to the Internet and Existing PLCs and Drives

With embedded Ethernet and Web Server, the NX is Web-enabled and supports many Internet capabilities...including remote viewing, access, and programming over the Internet, and hosting Web pages and FTP sites. Our Web Server allows you to create custom Web pages and using available Web browser software, you can access information you need, when you need it remotely from any Internet access location in the world. For your other networking needs, Horner has a large library of third party protocols that allow any NX to easily connect to a variety of PLCs and Drives. This gives you the option to network the NX to existing control systems in your plant or factory...and/or use the NX as a display.



NX250 Graphical OCS

Under \$700

CompactFLASH

Embedded Ethernet

Web-Enabled

Free Software

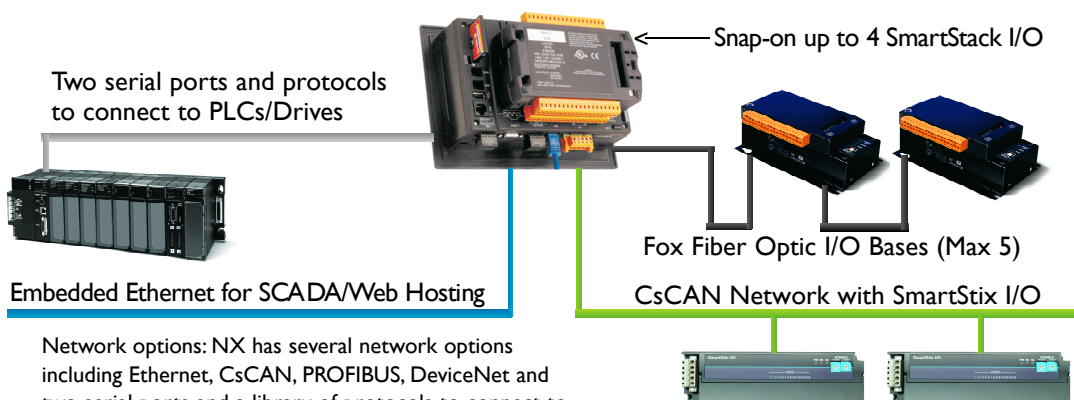

Network options: NX has several network options including Ethernet, CsCAN, PROFIBUS, DeviceNet and two serial ports and a library of protocols to connect to most PLCs and Drives.

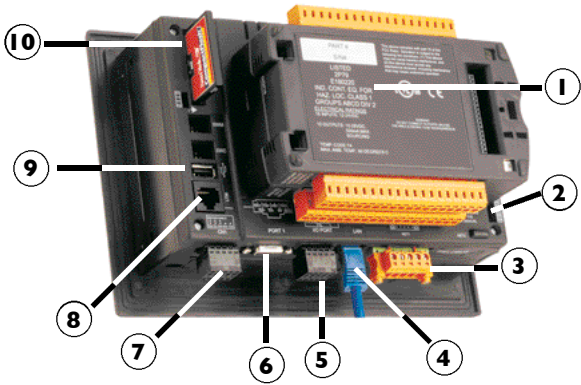

1	SmartStack Snap-on I/O
2	Fox Fiber Optic I/O Ports
3	CsCAN Network Port
4	Ethernet Port
5	HSC and PWM Inputs/Outputs
6	Serial Port 1 (9 pin)
7	Serial Port 2
8	Serial Port 1 (RJ-45)
9	USB Programming Port (future)
10	CompactFLASH Slot

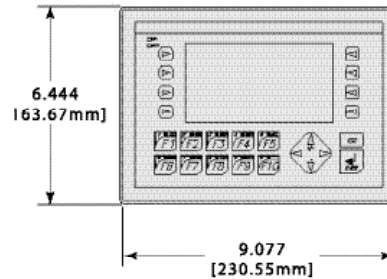
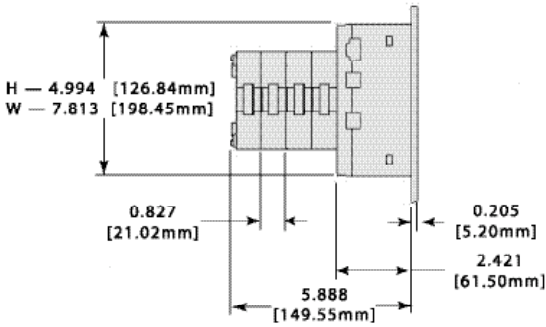

Part Number Description

HE-NX220	NX Operator Control Station with 128 X 64 LCD Screen, CompactFLASH slot
HE-NX221	NX Operator Control Station with 128 X 64 LCD Screen, Ethernet, CompactFLASH slot, Web Server and built-in HSC and PWM
HE-NX250	NX Operator Control Station with 240 X 128 LCD Screen, CompactFLASH slot
HE-NX251	NX Operator Control Station with 240 X 128 LCD Screen, Ethernet, CompactFLASH slot, Web Server and built-in HSC and PWM

Note: NX models require plastic SmartStack I/O modules if snapped-on back.

Specifications

Specification	NX220	NX221	NX250	NX251
Application Programming Environment	Cscape (ladder logic plus screen development) or IEC-61131 Programming Languages			
Web Server	No	Yes	No	Yes
Ladder Logic Memory	256K Bytes			
Register (Reference) Memory	32K Bytes			
Logic Scan Rate	0.1mS/K (typical)*			
CompactFLASH	Yes	Yes	Yes	Yes
Built-in >1 MHz HSC and PWM	No	Yes	No	Yes
Display Technology	Backlit LCD			
Display Size	128 X 64	128 X 64	240 X 128	240 X 128
Function Keys with LEDs (Soft Keys)	10(4)	10(4)	10(8)	10(8)
Application Memory – Graphics	1MByte			
I/O Supported (Number I/O)	SmartStack Snap-on I/O** and SmartStix Remote I/O (4096 digital, 1024 analog)			
FOX Fiber Optic I/O Supported	Yes	Yes	Yes	Yes
Networking	CsCAN and 2-Serial Ports (each RS-232 or RS-485)			
Embedded Ethernet	No	Yes	No	Yes
Supports PLC/Drive Protocols	Yes	Yes	Yes	Yes

* Total ladder scan is impacted by several factors—logic, I/O, screen, and communications updates.

** NX models require plastic SmartStack I/O modules if snapped-on back.



NX220 128 X 64 Screen Model

PLC/Drive Protocols

Built-in >1 MHz HSC and PWM

Complex Graphical Objects

Full Alarming Package

Downloadable Fonts

Four Selectable Languages

Horner APG

USA 877-665-5666 or 317-916-4274

Europe (+353) 21-4321266

www.hornerOCS.com

Cscape, SmartStack, SmartStix and CsCAN are registered trademarks of Horner APG, LLC. ©2005 Horner APG, LLC PS/5-6-05

